







Product Features

Motor Type	Remote (External Mounting)
Cooking Coverage	Suits 90cm - 130cm Cooking Surfaces
Filtration Type	Baffle Filters x 3
Lighting	LED 4 x 1.2 W (3200 K)
Finish	AISI304 Scotch Brite Stainless
Controls	Touch Control (Remote Control Included)
Speed Settings	3 Speed + Boost
Timer Functions	15min Auto Shut-Off
Ducting	200mm circular outlet 5 x Meters of Flexi Duct Supplied
Hood Width	1160mm
Hood Depth	470mm
Hood Height	332mm (Inc. Outlet)

Filtration Zone



Dimensioned Drawing

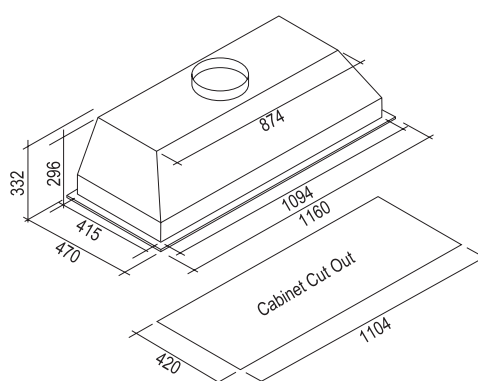

Model Code	Motor Output	Motor Solution
F3GV12S1-ER2010	2010 m ³ /h	External Roof Motor
F3GV12S1-EW2010	2010 m ³ /h	External Wall Motor



Product Features

Motor Type	Remote (External Mounting)
Cooking Coverage	Suits 90cm - 130cm Cooking Surfaces
Filtration Type	Baffle Filters x 6
Lighting	LED Strip Light 24W (5500 K)
Finish	AISI304 Scotch Brite Stainless
Controls	Touch Control (Remote Control Included)
Speed Settings	3 Speed + Boost
Timer Functions	15min Auto Shut-Off
Ducting	200mm Circular Outlet 5 x Meters of Flexi Duct Supplied
Hood Width	1200mm
Hood Depth	800mm
Hood Height	1257mm

Filtration Zone

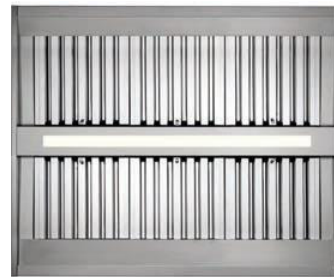

Dimensioned Drawing

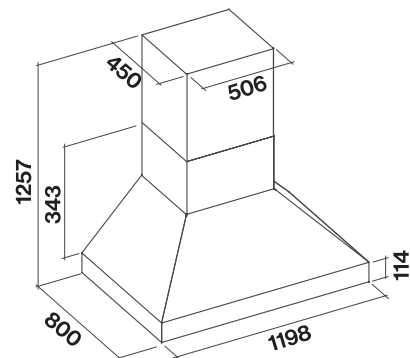

Model Code	Motor Output	Motor Solution
F5ME12S1-ER2010	2010 m ³ /h	External Roof Motor
F5ME12S1-EW2010	2010 m ³ /h	External Wall Motor



Product Features

Motor Type	Remote (External Mounting)
Cooking Coverage	Suits 90cm - 130cm Cooking Surfaces
Filtration Type	Baffle Filters x 6
Lighting	LED Strip Light 24 W (5500 K)
Finish	AISI304 Scotch Brite Stainless
Controls	Touch Control (Remote Control Included)
Speed Settings	3 Speed + Boost
Timer Functions	15min Countdown
Ducting	200mm Circular Outlet 5 x Meters of Flexi Duct Supplied
Hood Width	1200mm
Hood Depth	800mm
Hood Height	1100mm (max)

Filtration Zone



Dimensioned Drawing

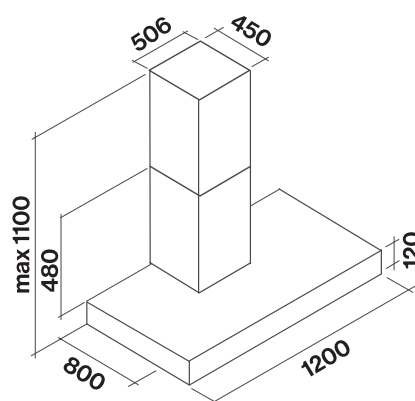

Model Code	Motor Output	Motor Solution
F5TN12S1-ER2010	2010 m ³ /h	External Roof Motor
F5TN12S1-EW2010	2010 m ³ /h	External Wall Motor



Product Features

Motor Type	Remote (External Mounting)
Cooking Coverage	Suits 90cm - 130cm Cooking Surfaces
Filtration Type	Baffle Filters x 3
Lighting	LED 6 x 1.2 W (3200 K)
Finish	AISI304 Scotch Brite Stainless
Controls	Touch Control (Remote Control Included)
Speed Settings	3 Speed + Boost
Timer Functions	15min Auto Shut-Off
Ducting	200mm Circular Outlet 5 x Meters of Flexi Duct Supplied
Hood Width	1200mm
Hood Depth	600mm
Hood Height	1290mm (max)

Filtration Zone



Dimensioned Drawing

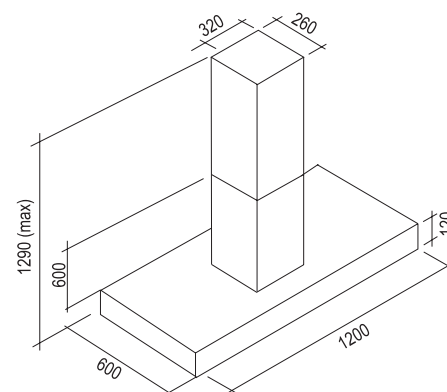

Model Code	Motor Output	Motor Solution
F7TN12S1-ER2010	2010 m ³ /h	External Roof Motor
F7TN12S1-EW2010	2010 m ³ /h	External Wall Motor

REMOTE MOTOR SOLUTIONS

EXTERNAL ROOF SOLUTION

765, 1140 & 2010m³/h

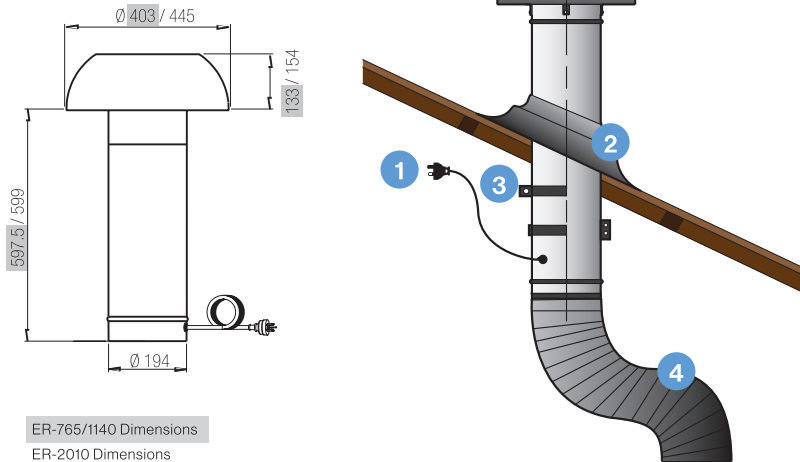

ER-765/1140 Dimensions
ER-2010 Dimensions

1. Fan power supply connects to internal hood unit
2. Tile or metal roof flashing (optional accessory)
3. Rigid duct mount (optional accessory)
4. 200mm flexi ducting (attached to internal hood unit)*

**Advise to include gentle bend in duct run as well ensuring ducting is pulled tight and excess removed.*

We recommend to install the roof motor offset from rangehood to avoid direct noise travel.

EXTERNAL WALL SOLUTION

765, 1140 & 2010m³/h

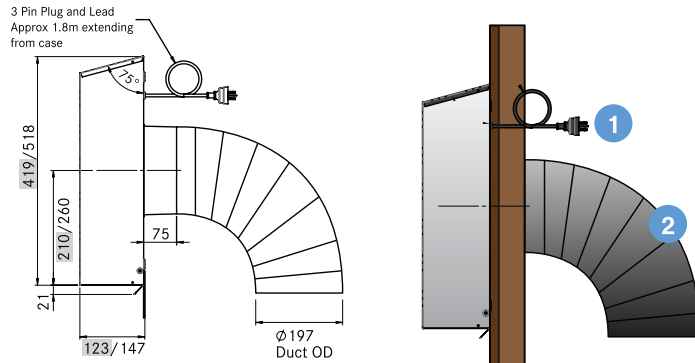

EW-765/1140 Dimensions
EW-2010 Dimensions

1. Fan power supply (connects to internal hood unit)
2. 200mm flexi ducting (attached to internal hood unit)*

**Advise to include gentle bend in duct run as well ensuring ducting is pulled tight and excess removed.*

IN-ROOF MOTOR SOLUTION

765 & 1140m³/h

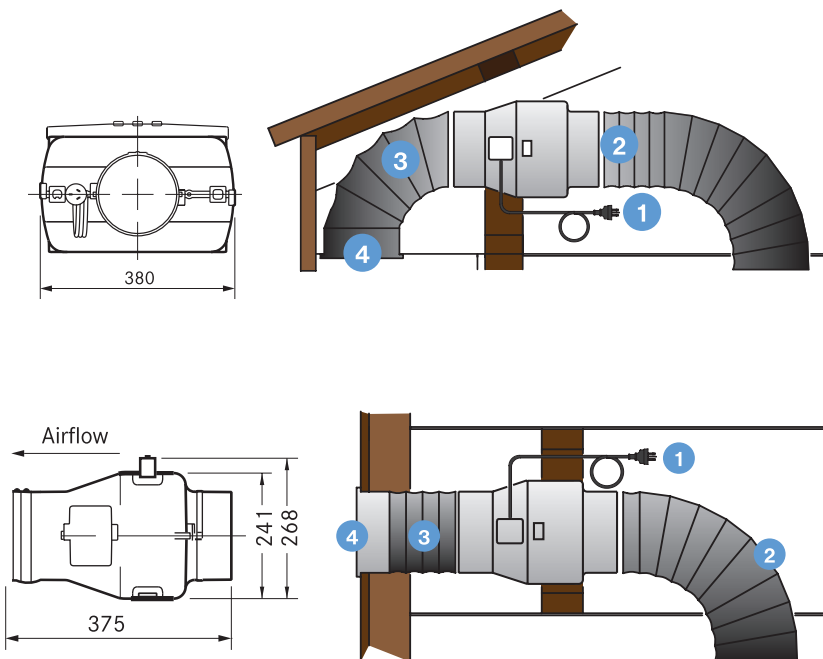

1. Fan power supply (attached to internal hood unit)
2. 200mm flexi duct installed between rangehood and motor inlet*
3. 200mm flexi duct installed between motor outlet and wall/eave vent
4. Vent installed in eave position

1. Fan power supply (attached to internal hood unit)
2. 200mm flexi duct installed between rangehood and motor inlet*
3. 200mm flexi duct installed between motor outlet and wall/eave vent
4. Vent installed in wall position

**Advise to include gentle bend in duct run as well ensuring ducting is pulled tight and excess removed.*

AVAILABLE ACCESSORIES

HBX200MET - 200MM METAL ROOF KIT

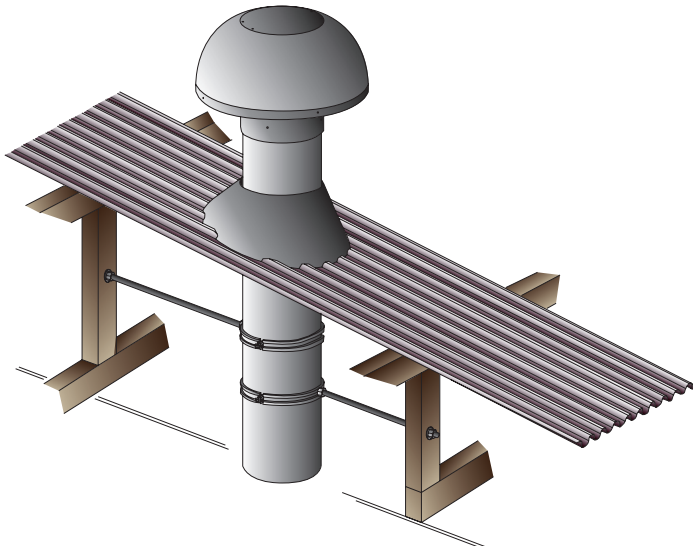

INCLUDED ACCESSORIES

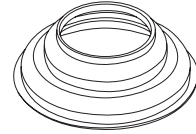

Metal roof flashing (x1)

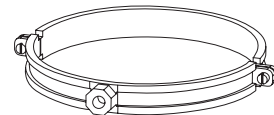

Rigid duct mount (x2)

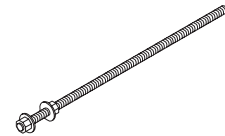

Threaded rod & fixings (x2)

HBX200TILE - 200MM TILE ROOF KIT

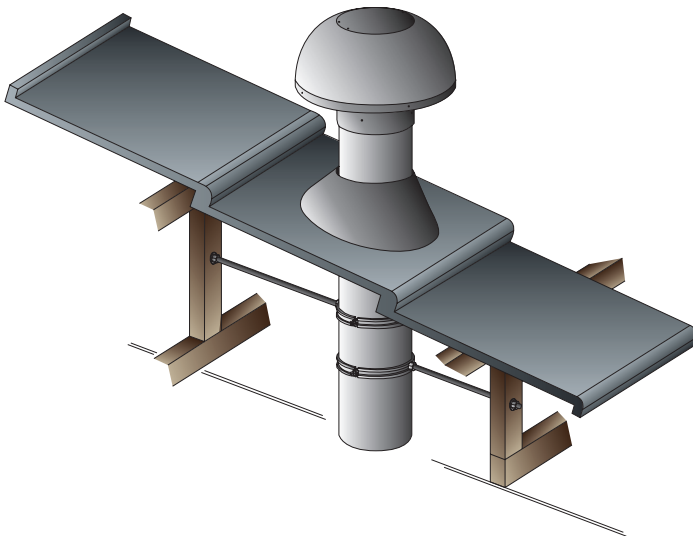

INCLUDED ACCESSORIES

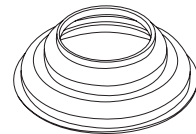

Tile roof flashing (x1)

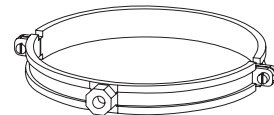

Rigid duct mount (x2)

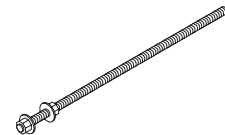

Threaded rod & fixings (x2)

FAN.RSK200 - 200MM BACKDRAFT DAMPER FOR EXTERNAL MOTORS

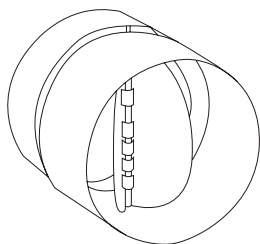

FAN.SJK200 - 200MM BACKDRAFT DAMPER FOR IN-ROOF MOTOR

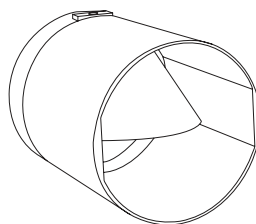

HBX200DUCT - DUCT EXTENSION KIT

